

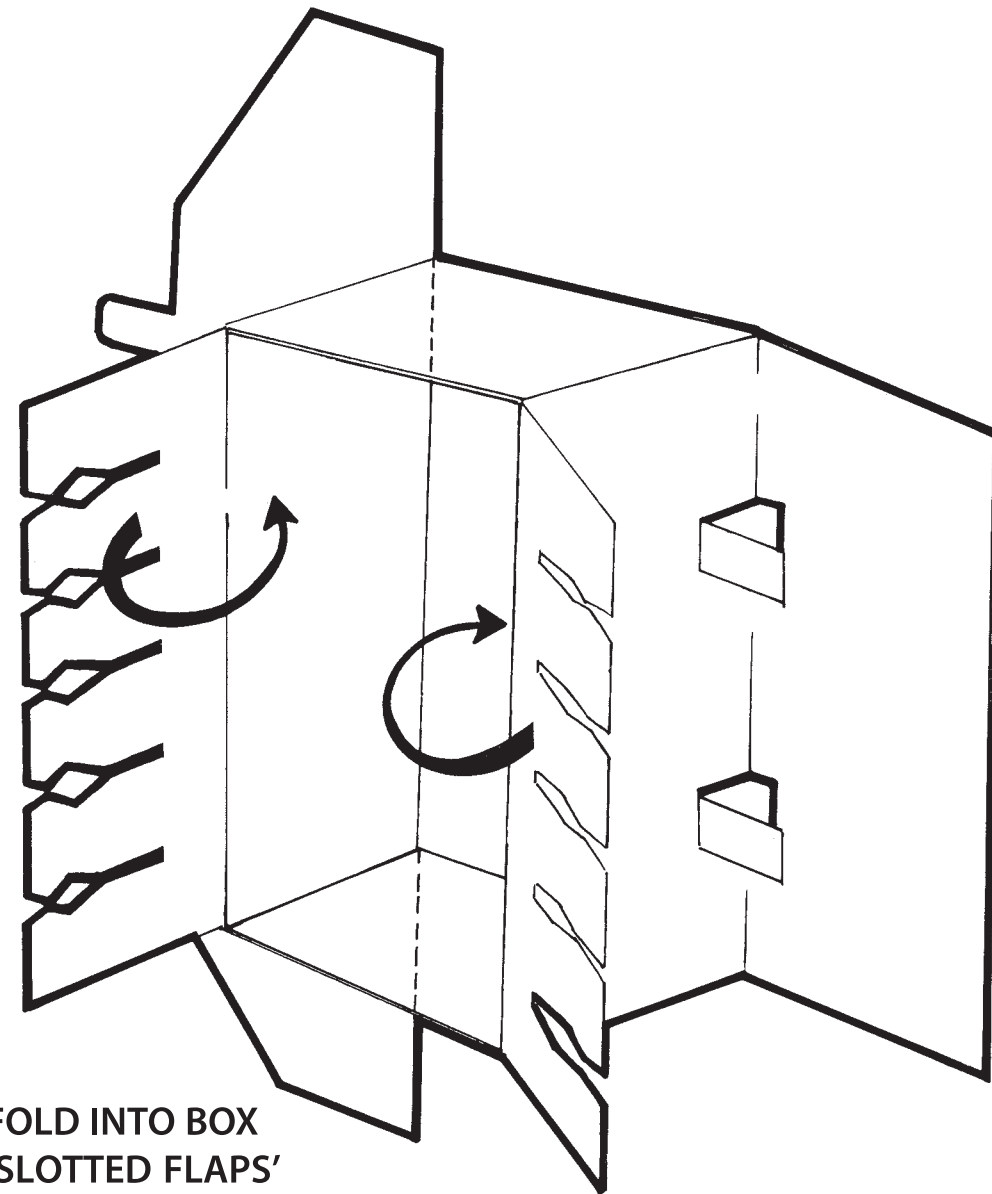

Stor A File® Assembly Instructions

A. OUTER SHELL



A. Prepare outer shell by folding the slotted flaps as shown.

B. DIVIDERS

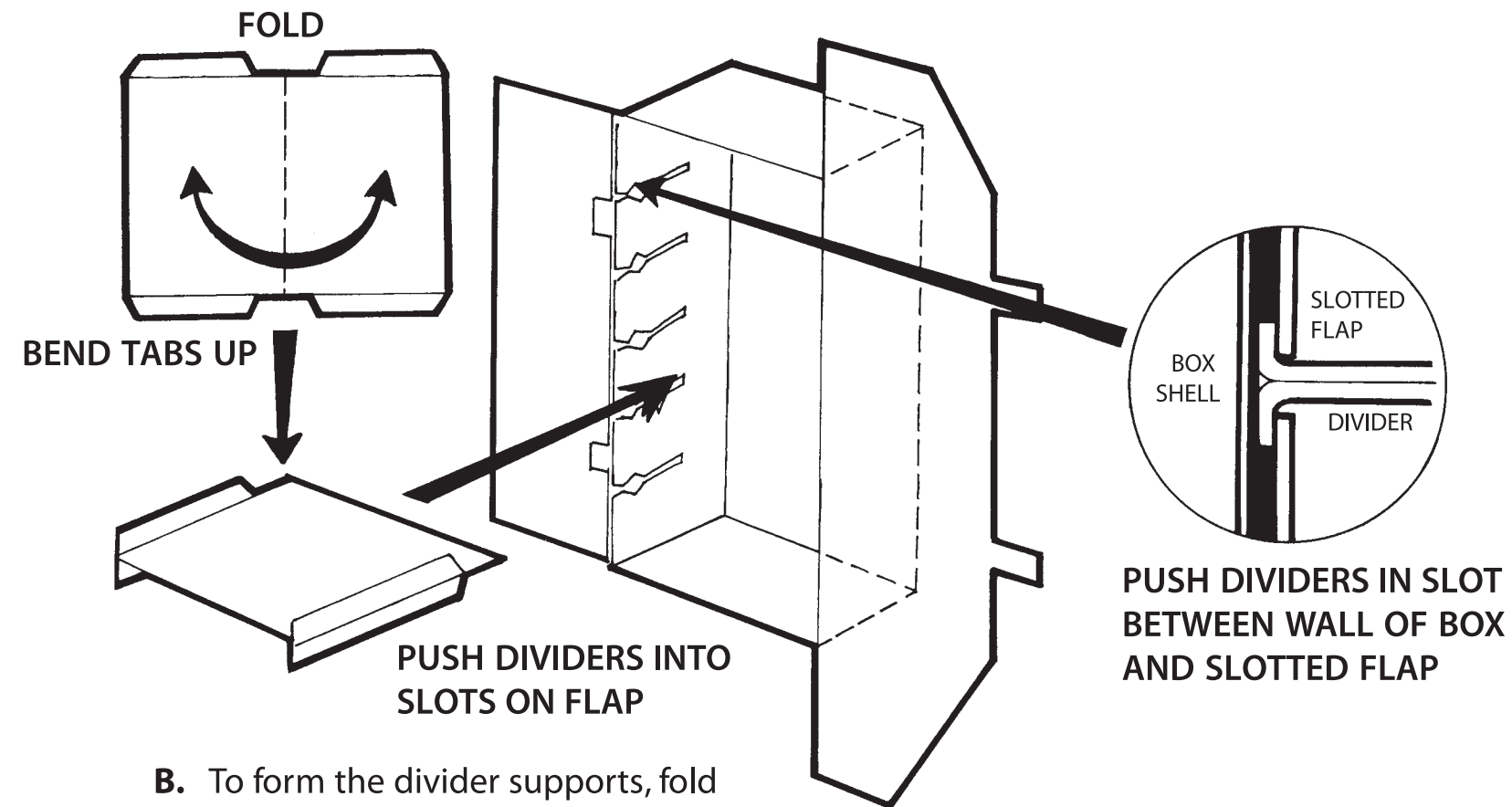

B. To form the divider supports, fold the dividers panels in half then bend up tabs. Push the dividers into the slotted flaps in the rear of the outer shell as shown.

C. THE BACK

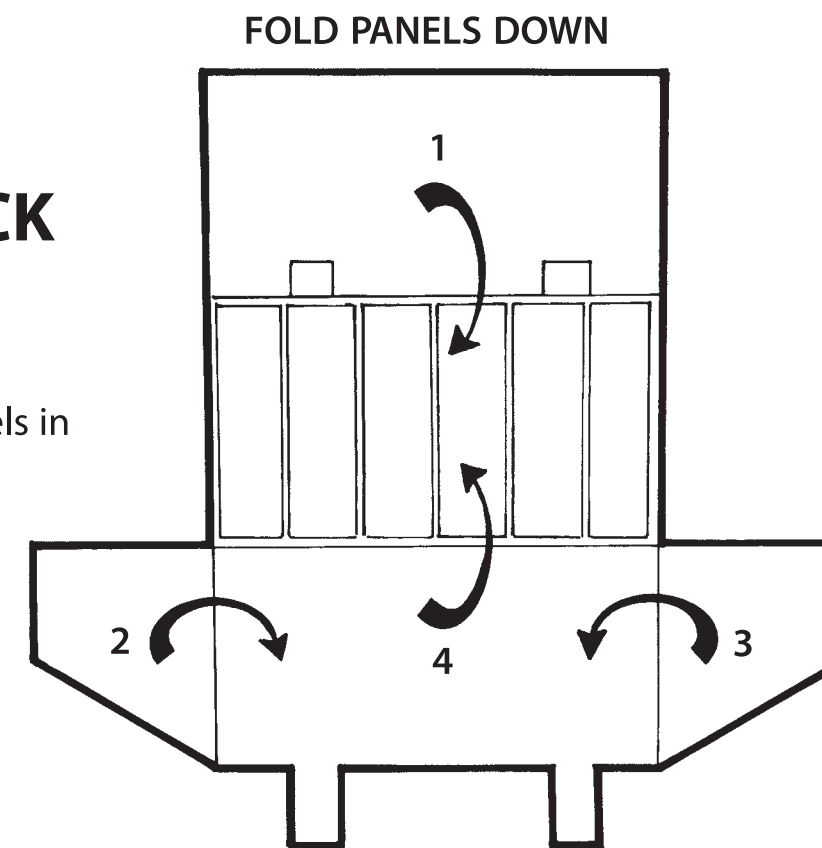

C. To form the back fold panels in sequence shown.

D. TO SECURE BACK

LOCKING TABS 1

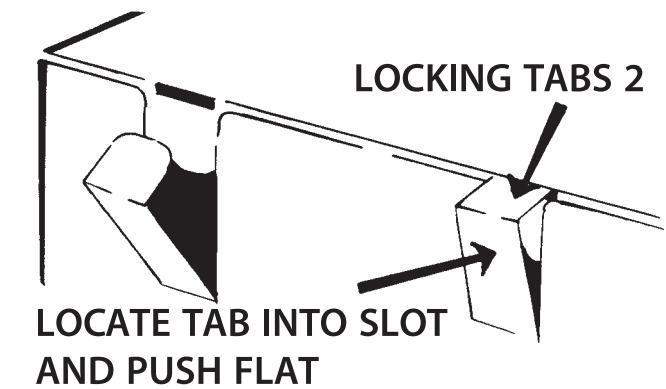
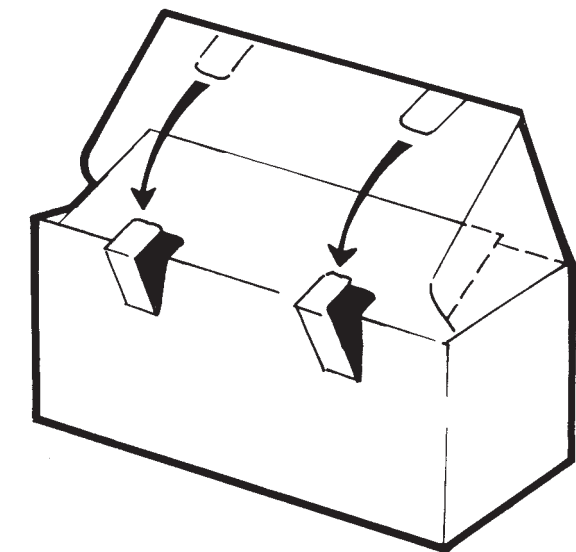

D. To secure back push locking tabs '1' into slots.